



Ultrasonic Cool Mist
Smart Humidifier
User Manual
H500 Pro

Please read all the instructions before using and keep it for future reference.



WARRANTY

Welov comes with 1 Year Warranty that begins on the date of purchase.

Welov Corporation warrants all products to be of the highest quality in material, craftsmanship, and service, effective from the date of purchase to the end of the warranty period. The warranty applies to the product and necessary parts and labor relating thereto. The warranty does not apply to damage resulting from failure to follow the operating instructions, accidents, abuse, alterations, or disassembly by unauthorized individuals.

Extend Your Warranty by 1 Year

Register your product at www.welovhome.com/registration to extend your 1-year warranty by an additional year.

Please fill out all required fields and include your order ID, place of purchase, and purchase date, if applicable.

If you have product questions or concerns, don't hesitate to contact us directly at:

support@welovhome.com

Welov has an award-winning warranty, exchange, and customer service program that guarantees hassle-free solutions within 24 hours for any issue you might have with this product!

CONTENTS

IMPORTANT SAFETY INSTRUCTIONS -----	01
BEFORE USING THE HUMIDIFIER -----	01
WHEN USING THE HUMIDIFIER -----	02
AFTER USING THE HUMIDIFIER -----	04
WHAT'S INCLUDED -----	05
SPECIFICATIONS -----	05
PRODUCT OVERVIEW -----	06
OPERATION GUIDE -----	08
ADD WATER -----	08
OPEN/CLOSE NOZZLE -----	09
POWER ON/OFF AND MIST CONTROL -----	10
BOOSTMIST -----	11
HUMIDITY SETTING -----	11
NIGHT LIGHT -----	12
TIMER ON -----	12
TIMER OFF -----	13
SLEEP MODE -----	14
MEMORY FUNCTION -----	15
LOW WATER PROTECTION -----	15
User Guide for AiDot APP -----	16
MAINTENANCE AND CARE -----	17
DAILY MAINTENANCE -----	17
WEEKLY MAINTENANCE -----	18
DUSTPROOF SPONGE CLEANING -----	21
END-OF-SEASON CARE AND STORAGE -----	22
TROUBLESHOOTING GUIDE -----	22
AiDot APP TROUBLESHOOTING -----	26

IMPORTANT SAFETY INSTRUCTIONS

Please read these IMPORTANT SAFETY INSTRUCTIONS before using the humidifier. Some issues could be avoided by doing so during the use of the product, but it is not necessary to follow these instructions completely for operating the humidifier.

- Be aware that high humidity levels may encourage the growth of biological organisms in the environment.
- Do not permit the area around the humidifier to become damp or wet. If dampness occurs, turn the output of the humidifier down. If the humidifier output volume cannot be turned down. Use the humidifier intermittently. Do not allow absorbent materials such as carpeting, curtains, drapes, or tablecloths to become damp.
- Unplug the appliance during filling and cleaning.
- Never leave water in the reservoir when the appliance is not in use.
- Empty and clean the humidifier before storage. Clean the humidifier before next use.
- Warning: Micro-organisms that may be present in the water or in the environment where the appliance is used or stored, can grow in the water reservoir and be blown in the air causing very serious health risks when the water is not renewed and the tank is not cleaned properly every 3 days.
- Empty the tank and refill every third day. Before refilling, clean it with fresh tap water or cleaning agents if required by the manufacturer. Remove any scale, deposits, or film that has formed on the sides of the tank or on interior surfaces, and wipe all surfaces dry.

BEFORE USING THE HUMIDIFIER

1. DO NOT place the humidifier in a wet environment.

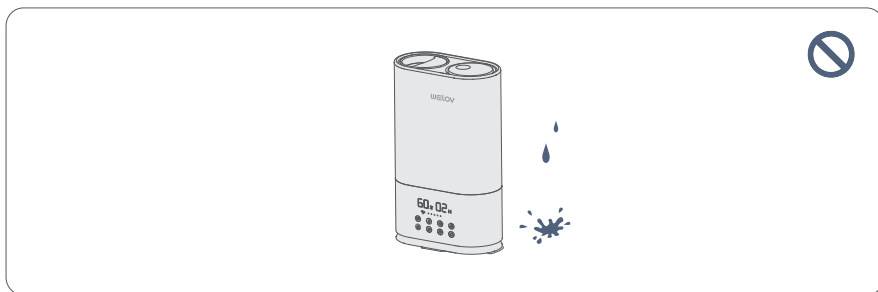

2. Please always keep the humidifier out of the reach of patients, children, and pets.

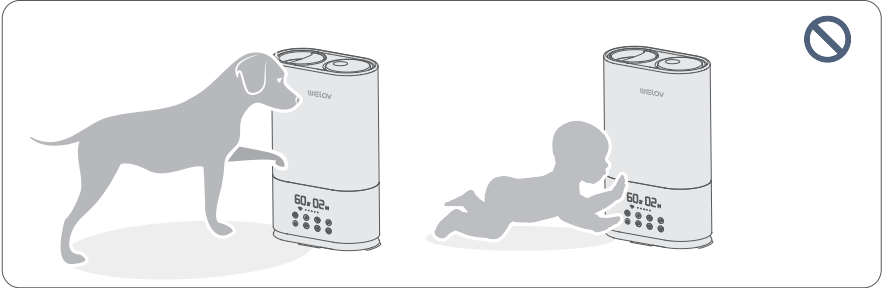

3. Please always place the humidifier on a smooth, flat, lint-free, non-metallic, waterproof and level surface; avoid the direct sunlight.

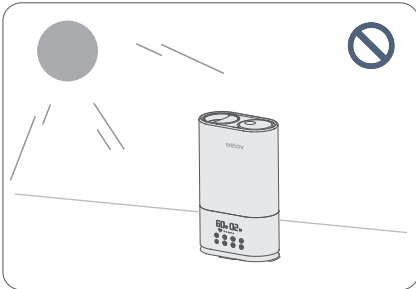

4. DO NOT place the humidifier near open flames or heat sources, such as stoves, ovens, radiators or computers.

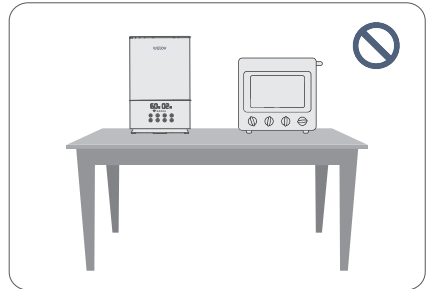

WHEN USING THE HUMIDIFIER

1. DO NOT plug the power adapter into an outlet with wet hands.

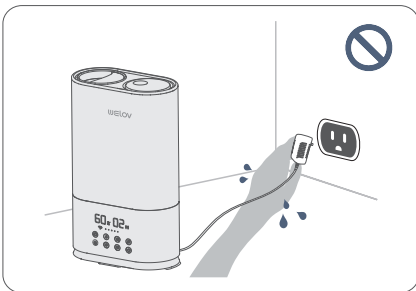

2. DO NOT make the **Nozzle** facing towards the wall or curtains.

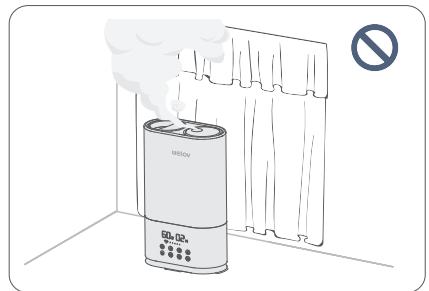

3. DO NOT cover the **Nozzle** with your hand or any other objects when the humidifier is working to avoid damage to the humidifier or injury.

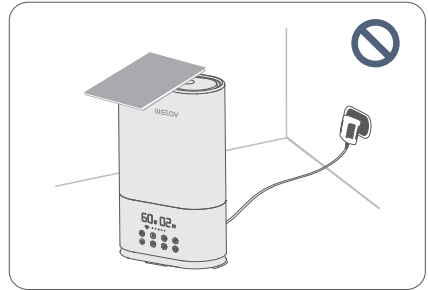

4. DO NOT clean the humidifier when it is connected to a power source or when it is turned on.

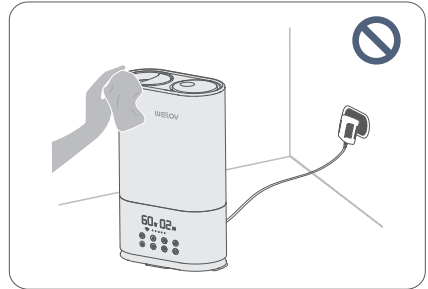

5. DO NOT move or tilt the humidifier during operation.

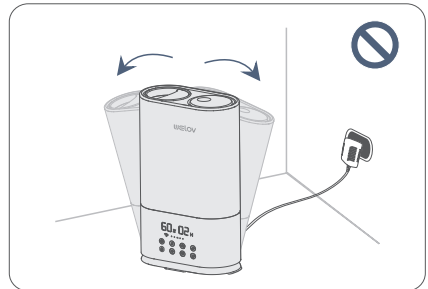

6. The recommended ideal humidity is between 40% - 60%. Please adjust the mist as needed.



AFTER USING THE HUMIDIFIER

1. Always disconnect the power adapter by unplugging it when the humidifier is not in use.

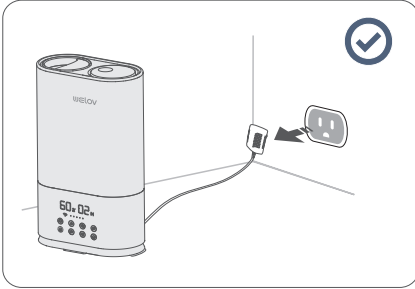

2. The humidifier requires regular cleaning. Please refer to the instructions mentioned in the section of **Maintenance and Care**.



3. DO NOT clean the humidifier immediately after turning it off. Allow the humidifier to cool down completely before cleaning.

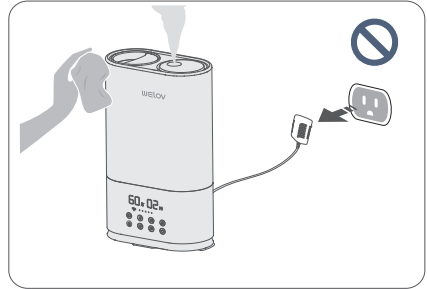

4. DO NOT attempt to repair, or adjust any electrical/mechanical functions of the humidifier by yourself.

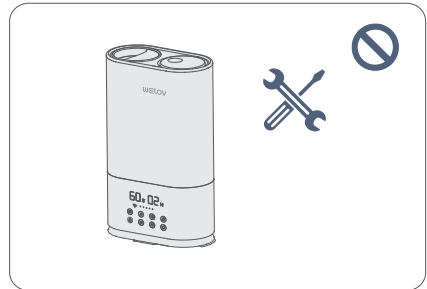

Welov will accept no liability or responsibility for fires, explosions or electrical shocks caused by improper operation, dismantling the humidifier or by not adhering to the above safety instructions.

WHAT'S INCLUDED

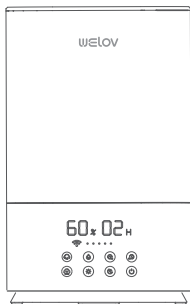

Humidifier



Dustproof Sponge



Power Adapter



Cleaning Brush



Sealing ring



User Manual

SPECIFICATIONS

Model	Welov H500 Pro
Adapter Input	AC 100-240V; 50/60Hz
Adapter Output	DC 32V 1.1A
Rated Input	DC 32V
Rated Power	35.2W
Water Tank Capacity	6L / 1.59Gal
Dimensions	406 x 250 x 131mm / 15.98 x 9.84 x 5.16 inches
Net Weight	2420g / 85.4oz
Atomization Amount	60-500ml / H

PRODUCT OVERVIEW

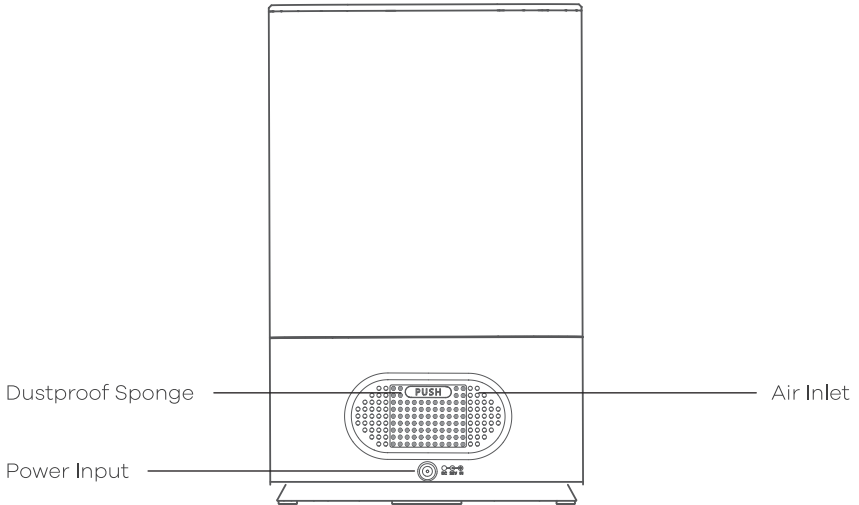
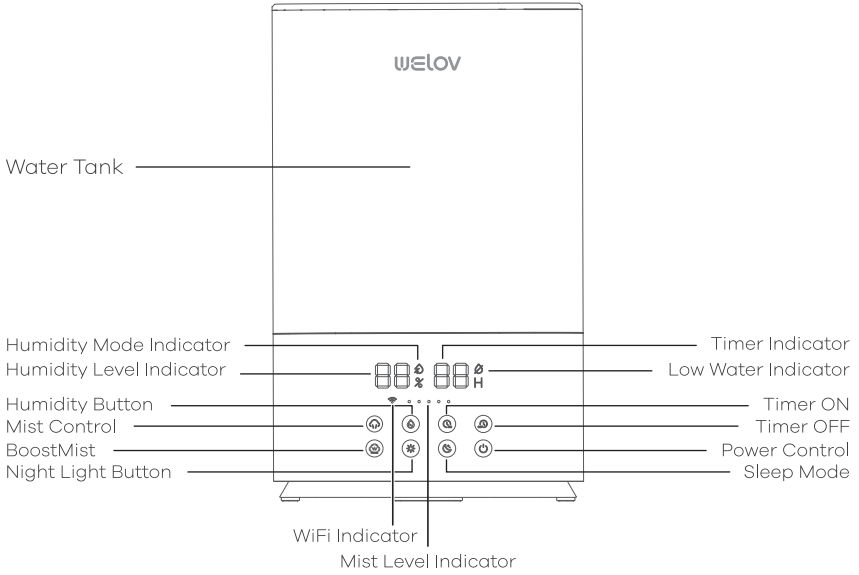

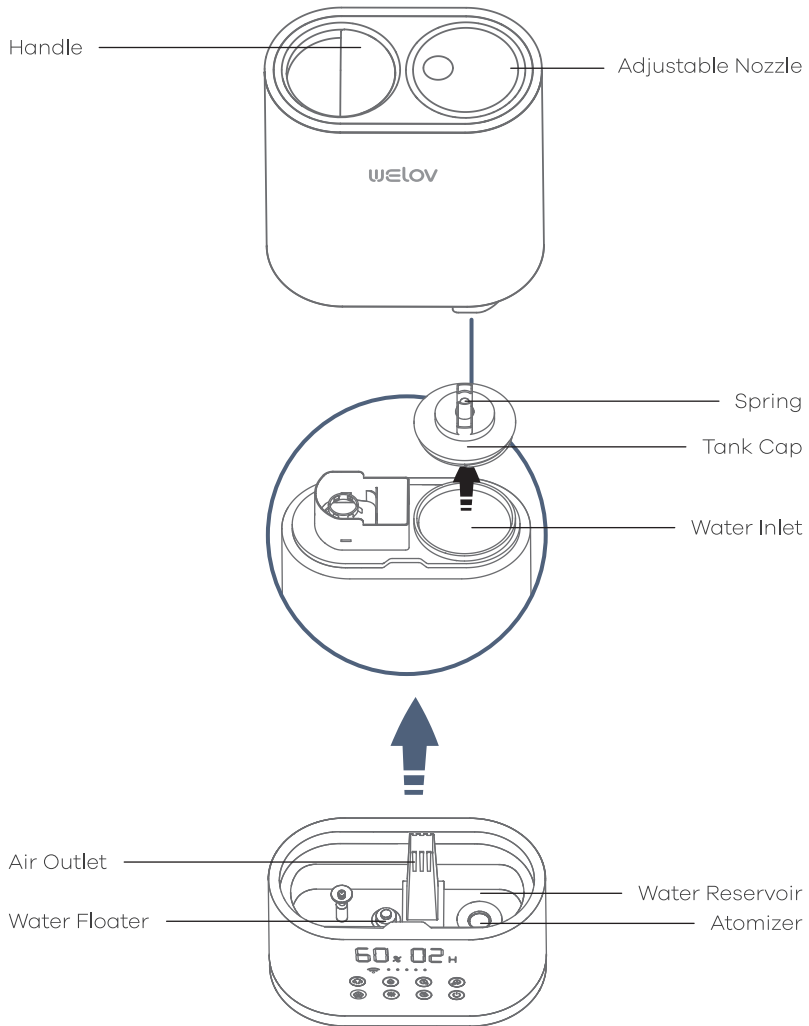

OPERATION GUIDE

ADD WATER

1. Separate the **Water Tank** from the **Base**, turn the **Water Tank** upside down (①), loosen the **Tank Cap** (②③), then fill the tank with clean cool water (④).

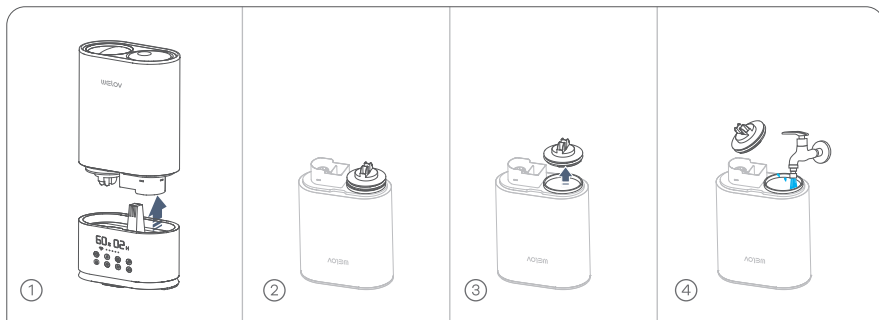

2. Tighten the **Tank Cap** (⑤), then turn the **Water Tank** upright and put it back on the **Base** (⑥).

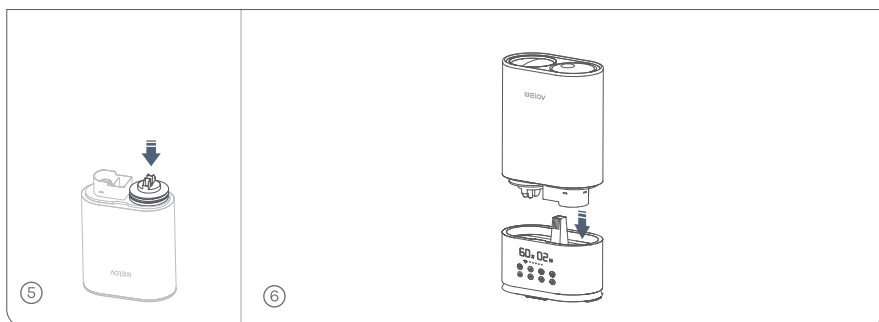

Tips:

1. Make sure that the **Water Tank** and the **Base** are well fitted so that the water can go to the **Water Reservoir**.
2. Please make sure that the sealing ring is well installed on the **Tank Cap**.

Important:

- ① If the tap water is too hard, we recommend using the filtered or distilled water to avoid white dust. DO NOT use hot water.
- ② DO NOT add any essential oils or medicinal tablets into the **Water Tank**.
- ③ DO NOT add water into the **Base** or through **the Nozzle**.
- ④ DO NOT move the humidifier while the **Water Tank** is full of water to avoid leakage or **Base** overfilling.

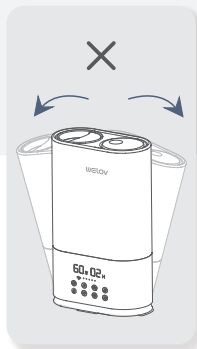
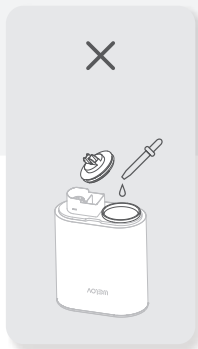
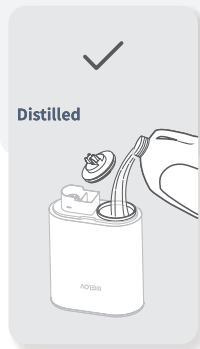

OPEN / CLOSE NOZZLE

Step 1:

Press the top of NOZZLE, the NOZZLE will open on 60°.

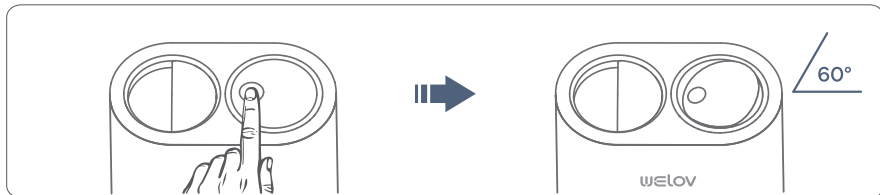

Step 2:

Press again the top of NOZZLE, the NOZZLE will open on 65°.

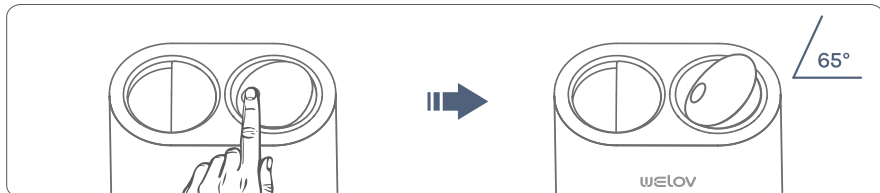

Step 3:

Press the top of NOZZLE when the nozzle closing, the NOZZLE will close.

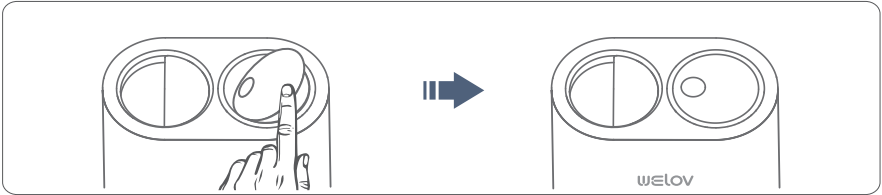

Tips:

The best MIST condition is NOZZLE on 65°.

🔌 POWER ON/OFF AND MIST CONTROL

Step 1:

Connect the **Power Adapter** to the humidifier and plug it into the socket. Open the **NOZZLE**.

Step 2:

Press the **Power Control** to turn on the humidifier. The **display area** and **Mist Level Indicator** will light up in solid white at the same time, and the mist will be the minimum level by default.

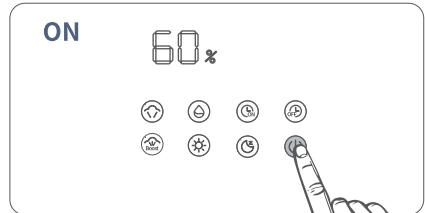

Step 3:

There are five mist options for this humidifier, which include 1(lower), 2(low),3(medium),4(high),5(higher). When the unit is on, press the **Mist Control** to cycle through five mist options, and the Mist level indicator will light up.

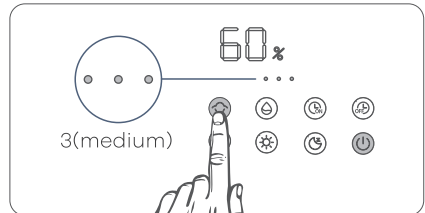

Step 4:

Press the **Power Control** again to turn off the humidifier and **Mist Level Indicator** will be off.

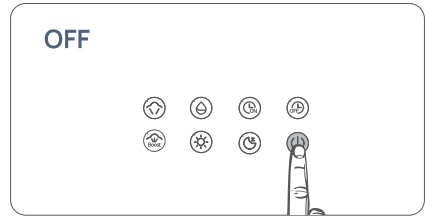

BOOSTMIST

Step 1:

Press the **BoostMist** button to adjust the mist to maximum intensity.

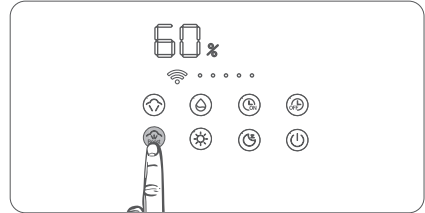

Step 2:

30 minutes later the mist intensity will automatically return to the state before activating this function. Or press the **BoostMist** button again

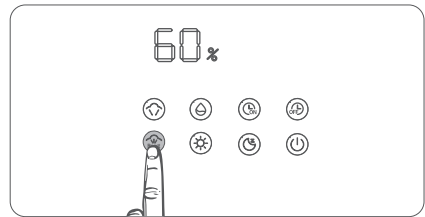

HUMIDITY SETTING

Step 1:

Press the **Humidity Button** to set the humidity level from 30% to 95% with an increase/ decrease of 5% in each tap.

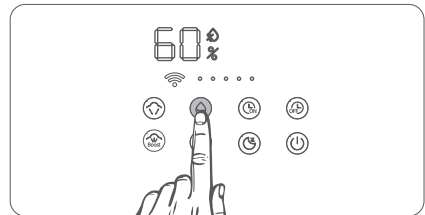

Step 2:

The humidity level set will flicker three times to confirm your setting.

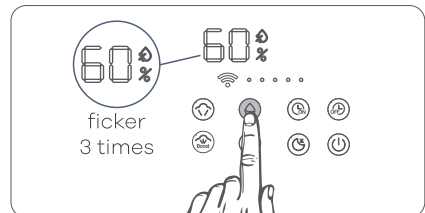

The most comfortable environmental humidity is between 40%-60%. Please adjust the mist as needed.

NIGHT LIGHT

- 1 Press the **Night Light** button to turn on the light at the bottom. The default brightness is set to the medium level.



- 2 Long press the **Night Light** button for 1.5S to adjust the brightness.



- 3 Press the **Night Light** button again to turn off the light at the bottom.



TIMER ON

Step 1:

When the power is standby, Press the **Timer ON** button to set the time level from 00H to 12H with an increase/decrease of 1H in each tap.

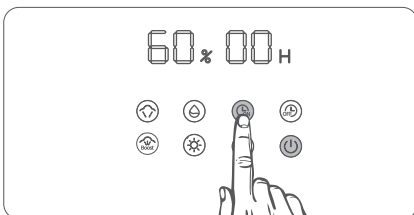

Step 2:

Press the **Timer ON** button for the 00H to disable the Timer function, and the Timer Indicators will be off.

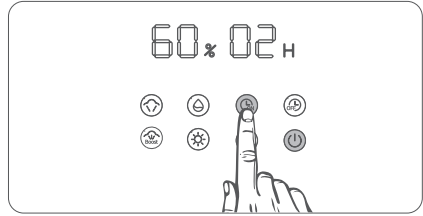

Step 3:

Long press the **Timer ON** button for 1.5S to cancel the timer setting immediately.

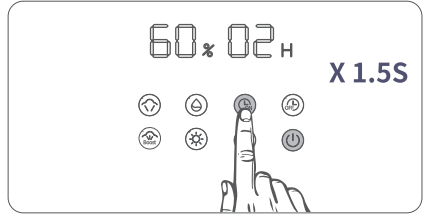

Tip:

Night Light function can be used alone when the humidifier is not producing mist.

TIMER OFF

1 When the unit is on, Press the **Timer OFF** button to set the time level from 00H to 12H with an increase/ decrease of 1H in each tap.

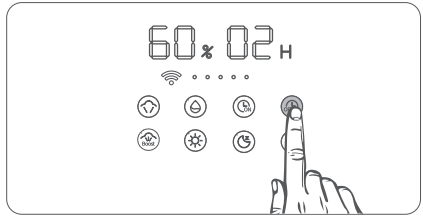

2 Press the **Timer OFF** button for the 00H to disable the Timer function, and the Timer Indicators will be off.

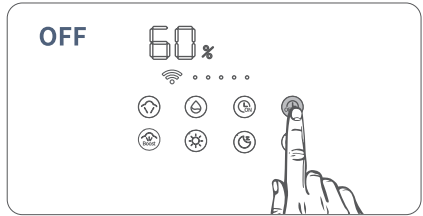

3 After the **Timer** is up the humidifier will stop producing mist and the **Water Level Indicator** will be off.

Tip:

Night Light function is not affected by the **Timer**.

- 4 Long press the **Timer OFF** button for 1.5S to cancel the timer setting immediately.



SLEEP MODE

- 1 Press the **Sleep Mode** button to enable the **Sleep Mode**. All lights, including **Water Level Indicator**, **Low Water Indicator**, **Timer Indicator** and **Night Light** will be off, and the humidifier will continue to produce mist.

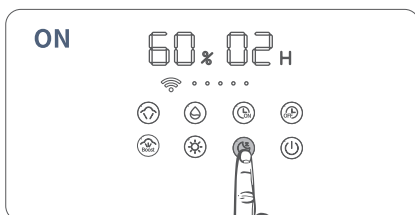

- 2 In the **Sleep Mode**, press any button or the **Power/Mist Control** to wake up the humidifier. The  icon will light up.

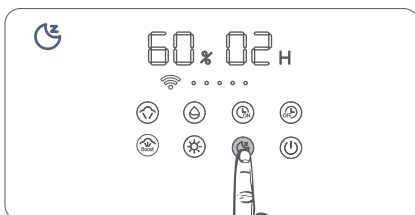

- 3 After waking it up, you can make some adjustment within 3S, such as setting a **Timer** or adjusting the **Night Light** brightness. After finishing the above settings for 1S, the humidifier will return to the **Sleep Mode**.

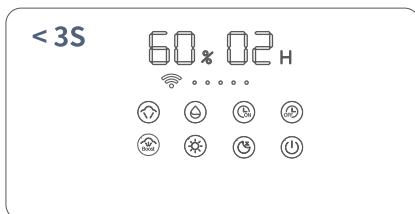

- 4 Press the **Sleep Mode** button again to exit the **Sleep Mode**, and the humidifier will return to the state before enabling the **Sleep Mode**.

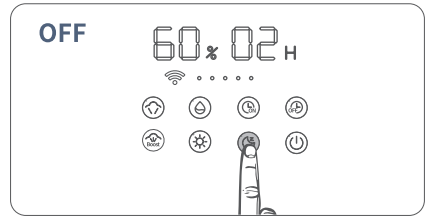

Tip:

If there is no operation within 3S, the humidifier will return to the state before waking it up.

MEMORY FUNCTION

- 1 If you turn off the humidifier without unplugging the adapter and then turn it on again, the mist intensity of the humidifier will be the same as before the humidifier was turned off.
- 2 If you turn off the **Night Light** without unplugging the adapter and then turn it on again the **Night Light** brightness will remain the same as before the light was turned off.

Tip:

The memory function does not apply to the **Timer** and **Sleep Mode** functions.

LOW WATER PROTECTION

When there is not enough water in the **Water Reservoir**, the **Low Water Indicator** and the  icon will turn red.

The humidifier will stop producing mist to prevent it from overheating and damaging the **Atomizer**.

User Guide for AiDot APP

APP Downloading and Installation

Option 1:

Search for **AiDot** from **App Store/Google Play**, then download and install it on your mobile device.

Option 2:

Scan the QR codes below to download and install.



For ios / Android

APP Registration and Login

Start the **ADot** APP and register with a valid email address for the first time to log in.

Note:

For a successful connection, please allow **AiDot** APP to use your WLAN & Cellular Data when running it.

CONNECTION MODE

IMPORTANT:



For the Humidifier:

Make sure the Humidifier has been plugged into a socket and powered on.

For WiFi network:

- ① Before connecting, please turn on location service/GPS on your phone and grant all the permissions required by AiDot APP.
- ② Make sure your mobile device is connected to a 2.4GHz WiFi.
- ③ Make sure you've entered the correct WiFi name and password when connecting.
- ④ Make sure the Humidifier, your phone and your router are close enough when connecting.

WiFi Connection

- To disconnect WiFi, press and hold  for 5 seconds until the WiFi indicator flicker. This will restore the smart humidifier's default settings and disconnect it from the AiDot APP.
- To reconnect WiFi, press and hold  for 5 seconds until the WiFi indicator turns on. Please follow the instructions in the AiDot app for adding a device.

Connection steps

- 1.1 Enter the Humidifier **Distribution network** interface.
- 1.2 Start the **AiDot APP** and tap **Add Device**.
- 1.3 Choose to add **Manually**.
- 1.4 Select **Lifestyle**, find the **Welov Humidifier**, then select the model.
- 1.5 After entering, click **Next**.
- 1.6 Turn on **WiFi, Bluetooth** and **location access** on your mobile device.
- 1.7 Confirm that the WiFi and password are correct.
- 1.8 click **Next**.
- 1.9 click **Connect**.
- 2.0 After successfully being added, you will have the option to rename the device and assign it to a location. It will now be listed on the app's home page. Tap the device listing to enter its control page.

MAINTENANCE AND CARE

Important:

① DO NOT submerge the **Base** in the water.

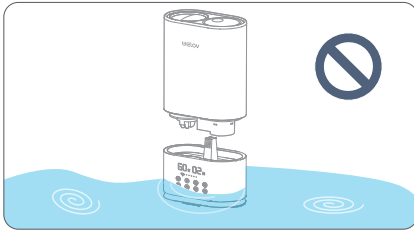

② DO NOT wash any parts of this humidifier in the dishwasher; otherwise, it will damage the humidifier.

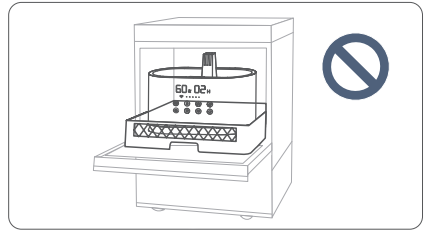

③ Make sure the water does not enter the **Base** through the **Air Outlet, Air Inlet** or **Power/Mist Control**.

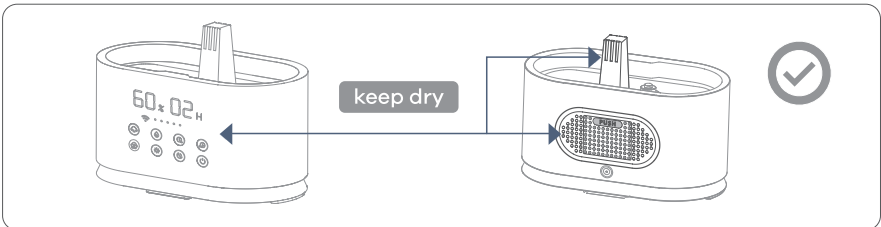

DAILY MAINTENANCE

- Step 1:** Turn off the humidifier and unplug the **Power Adapter** from the socket.
Step 2: Drain water from the **Water Tank, Water Reservoir, and Base**.

WEEKLY MAINTENANCE

- ① To properly clean your humidifier, we recommend that you remove scale and disinfect the humidifier separately.
- ② DO NOT mix vinegar and bleach solution. To avoid damage to the humidifier, do not use more than 1 teaspoon of bleach per gallon of water.
- ③ Please make sure the white sealing ring on the **Tank Cap** is installed correctly after cleaning to avoid water leakage.

Scale Removal Instructions

Step 1:

Turn off and unplug the humidifier.

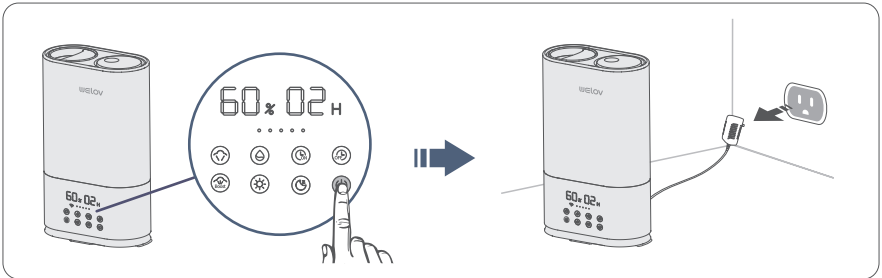

Step 2:

- ① Separate the **Water Tank** from the **Base**, then remove the **Tank Cap**. Make sure that the white sealing ring does not come off.
- ② Drain water from the **Water Tank** and **Base**, then remove all accessories and set aside.

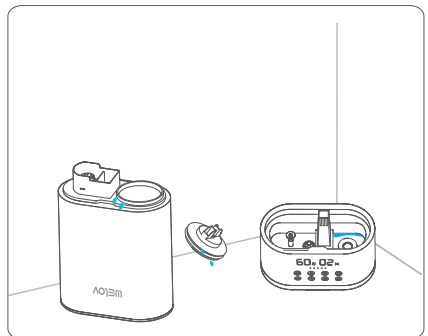
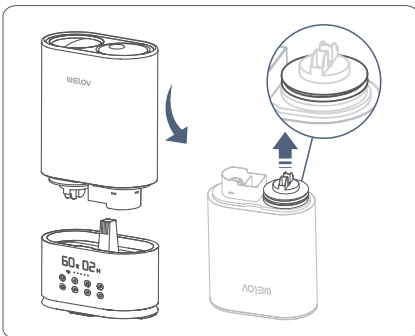

Step 3:

① Fill the **Water Tank** halfway. Add in 1 teaspoon of undiluted distilled white vinegar.



② Attach the **Tank Cap** and shake for 15 seconds.

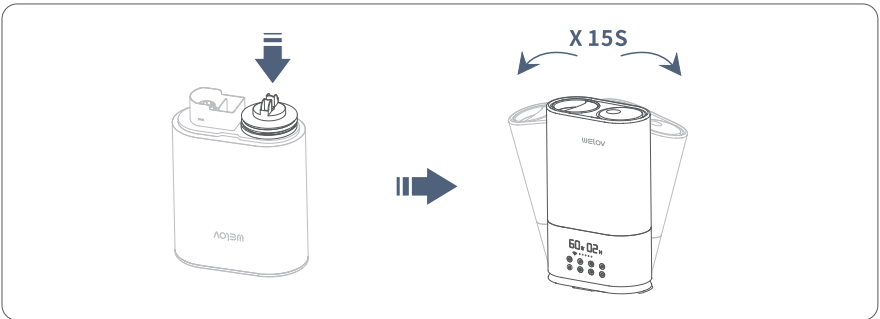

Step 4:

Place the **Water Tank** back to the **Base**. The vinegar solution will enter the **Water Reservoir** to loosen mineral scale on the **Atomizer**, **Water Floater** and the bottom of the **Water Tank**. Leave it for 15-20minutes.

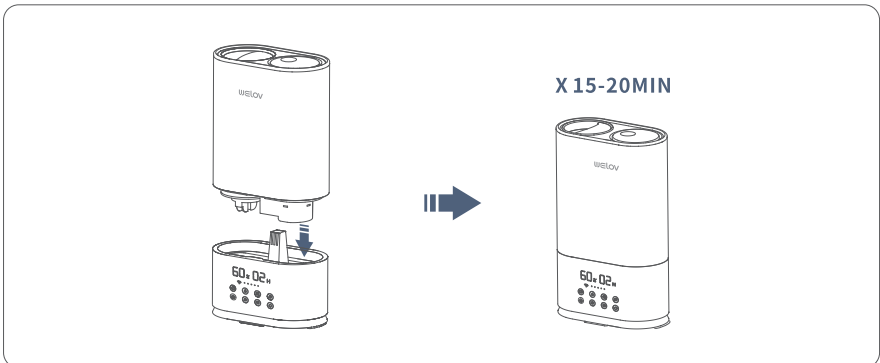

Step 5:

① Uncap the **Tank Cap** and drain the solution.

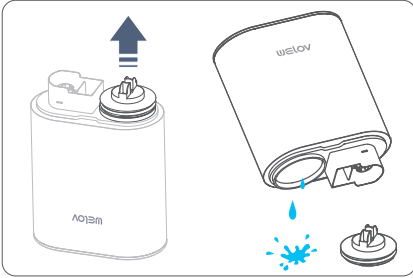

② Wipe the **Atomizer** and floater with a soft cloth to remove loose mineral deposits.

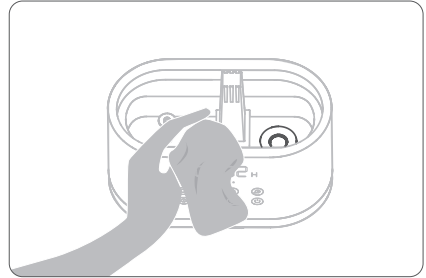

Step 6:

Wash both the **Water Reservoir** and **Water Tank** until the smell of vinegar (for scale removal) or bleach solution (for disinfection, see below) is gone.

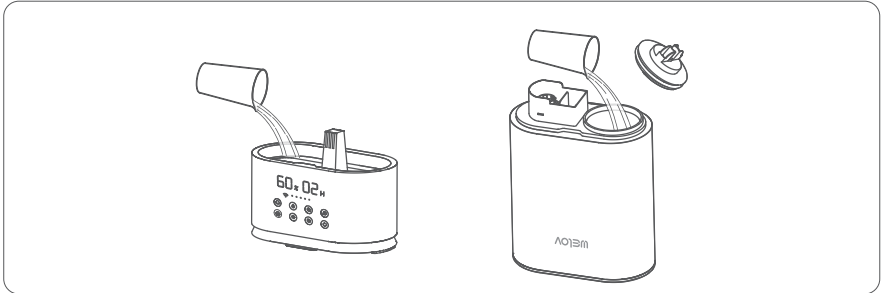

Disinfection Instructions

Step 1:

Follow steps 1 to 2 of the scale removal instructions in the previous section.

Step 2:

① Fill the **Water Tank** halfway. Add ½ teaspoon of bleach into the **Water Tank**.



② Attach the **Tank Cap** and shake for 15 seconds.

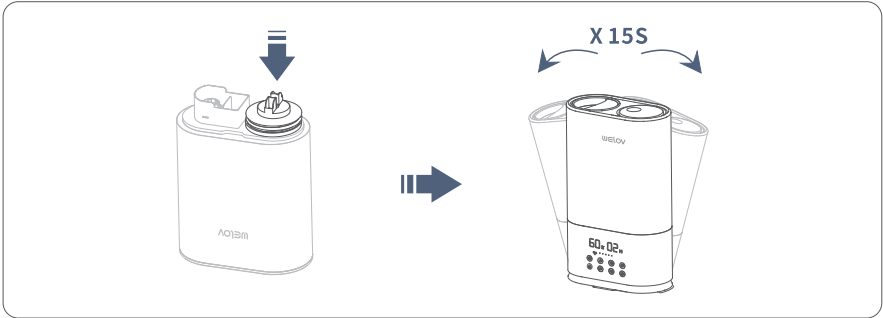

Step 3:

Place the **Water Tank** back to the **Base**. The bleach solution will enter and disinfect the **Water Reservoir** and the other components. Leave it for 15-20 minutes.

Step 4:

Follow steps 5 to 6 of the previous section for scale removal to complete the disinfection of the humidifier.

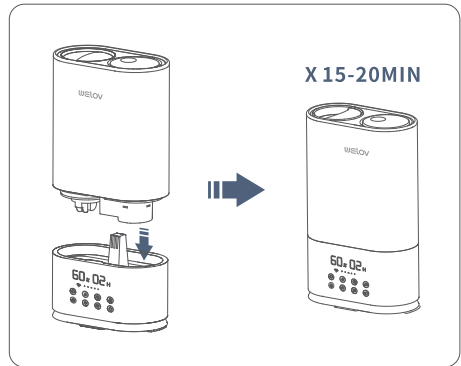

DUSTPROOF SPONGE CLEANING

Clean the **Dustproof Sponge** (located on the back of the **Base**) with water or detergent monthly, then put it back in place.

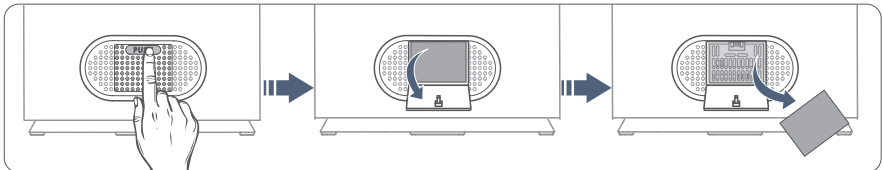

END-OF-SEASON CARE AND STORAGE

- 1 Follow the cleaning instructions when the humidifier will not be used for at least one week, or at the end of the season. Remove all accessories from the humidifier, and allow the humidifier and accessories to dry completely before storing it.
- 2 DO NOT store water in the **Base**, **Water Reservoir** or **Water Tank**.
- 3 Pack the humidifier safely and store it in a cool, dry place.

TROUBLESHOOTING GUIDE

- 1 If you need any further assistance, please feel free to contact us at support@welov.com.
- 2 Failure to keep the humidifier clean and free of mineral deposits may affect the operation of it.

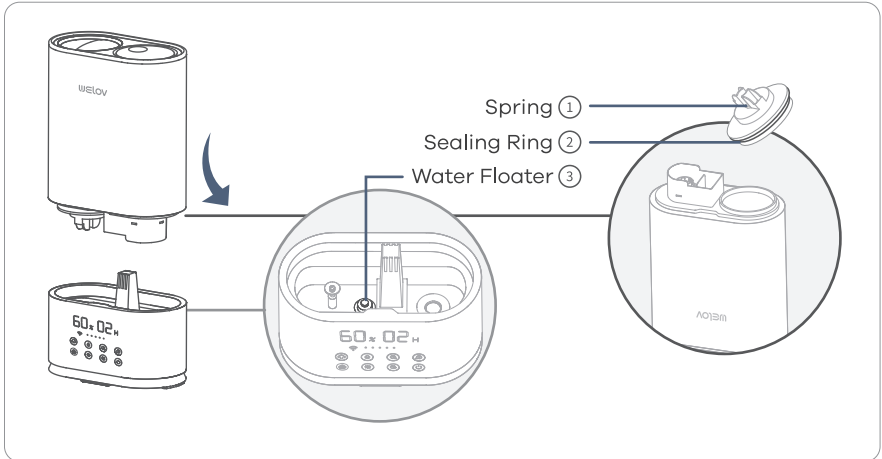

Q1. The water level indicator is off.

Possible Cause	Solution
The humidifier is not plugged in.	Make sure the humidifier is properly plugged into a socket.
No power from the power outlet.	Try to use other power outlets.
The humidifier is not turned on.	Check if the humidifier has been turned on.

Q2. The low water indicator stays red.

Possible Cause	Solution
No water in the Water Reservoir.	Make sure the ① Spring is fixed correctly to the bottom of the tank so that water can pass through to the Base.
③ Water Floater was stuck.	Adjust the ③ Water Floater to a horizontal position and make sure it can rise with water.

Q3. The water level indicator is white but there is no or little mist produced.

Possible Cause	Solution
Not enough water inside the tank.	Refill and place the Water Tank back in place.
Mist level is set too low.	Adjust the humidifier to the maximum mist.
Mineral build up on the Atomizer .	Check if any air comes out from the Nozzle If not, clean water scale on the Atomizer as instructed.
The Base might be overfilled.	Remove the tank, empty the Base , then place the filled tank on the empty Base .

Q4. Tank leakage.

Possible Cause	Solution
Tank may be damaged.	Check for possible cracks in the tank. If yes please replace it.
Tank Cap is not tightened securely.	Tighten the Tank Cap .
① Spring was stuck.	Make sure the ① Spring is fixed correctly to the bottom of the tank so that water can pass through to the Base.
② Sealing Ring was not installed on installed on the Tank Cap .	Make sure the ② Sealing Ring has been installed on the Tank Cap . Please contact us if it is lost.

Q5: The mist makes the surrounding tables or floors damp. Condensation occurs around humidifier or on windows/walls.

Possible Cause	Solution
Mist level is set too high for the room size.	1. Check if the room is too humid and adjust the humidifier to a lower mist 40%-60% works best. 2. Open door and windows or change to a larger room.
Air Inlet was blocked.	Make sure the humidifier is placed ≥ 12 inches away from the wall. Make sure the Nozzle is not facing the wall or window.
Low room temperature leads to liquefaction.	Adjust the room temperature to 25°C/77°F.

Q6. The humidification is too poor.

Possible Cause	Solution
Mist level is set too low for the room size.	1. Adjust the humidifier to the maximum mist. 2. Close door or windows to reduce air ventilation, or change to a smaller room.

Air Inlet was blocked.	Make sure the humidifier is placed ≥ 12 inches away from the wall. Make sure the Nozzle is not facing the wall or window.
Low room temperature leads to licauefaction.	Adjust the room temperature to 25°C/77F.

Q7: White dust appears or the black coating on the base flakes off.

Possible Cause	Solution
The tap water may contain too much minerals.	Please replace it with filtered or distilled water.

Q8: Strange odor.

Possible Cause	Solution
Please clean the humidifier.	<ol style="list-style-type: none"> 1. Please make sure to clean the humidifier according to the instructions. 2. Leave the empty Water Tank in a cool place for 12 hours without covering Tank Cap.

Q9: Strange water noise.

Possible Cause	Solution
Water is going down to the Water Reservoir .	This is normal while it is working

Q10: Humidifier is getting too hot.

Possible Cause	Solution
The humidifier works for too long.	Please power it off and put it in a well-ventilated place for 10 minutes.

AiDot APP TROUBLESHOOTING

Why isn't my humidifier connecting to the AiDot app?

- Make sure your phone has Bluetooth® turned on and is not currently connected to another Bluetooth device.
- During the setup process, you must be on a secure 2.4GHz Wi-Fi network. Confirm that the network is working correctly.
- Make sure the Wi-Fi password you entered is correct.
- Make sure your humidifier and phone are within 30 ft/10 m of each other.
- Reset the humidifier by pressing and holding  for 5 seconds. Then try connecting again.
 - a. Delete the humidifier from the AiDot app. Swipe left (iOS®) or press and hold (Android), then tap Delete. Then reconfigure your humidifier with the AiDot app.
 - b. Press and hold for 5 seconds. Then reconfigure your humidifier with the AiDot app.

My humidifier is offline.

- Make sure the humidifier is plugged in. The humidifier may appear to be offline if it is unplugged, or if the outlet does not have power.
- Refresh the AiDot menu by swiping down on the screen.
- Make sure your router is connected to the internet and your phone's network connection is working.
- Reset the humidifier using one of these options:

Note: Power outages, internet outages, or changing Wi-Fi routers may cause your humidifier to go offline.

The AiDot app is displaying an incorrect humidity percentage while the humidifier is turned on.

- The room may be larger than the humidifier's effective range. Move to a room smaller.
- Moisture may have built up inside the humidity sensor. Turn off the humidifier and allow the sensor to air dry. Make sure the nozzle is facing away from the sensor so that mist does not settle on the sensor.

If your problem is not listed, please contact Customer Support.

CAUTION

 The symbol indicates DC voltage



RECYCLING

Users should only operate the humidifier once they have understood all the following important safety instructions. Users who have a disability and need assistance are responsible for seeking support and ensuring their own safety in line with the instructions given in this manual.

*Children should be supervised to ensure that they do not play with the appliance.

*Unplug the appliance during filling and cleaning.

*Please confirm the composition and quantity of solution to be used during maintenance. If salt is included, it is recommended not to use excessive amounts of solution.

*The appliance is not to be operated from a dc supply-If the supply cord is damaged it must be replaced by the manufacturer, its service agent or similarly qualified persons in order to avoid a hazard.

*The appliance is only to be used with the power supply unit provided with the appliance.

FCC WARNING

This device complies with part 15 of the FCC Rules. Operation is subject to the following two conditions: (1) this device may not cause harmful interference, and (2) this device must accept any interference received, including interference that may cause undesired operation.

Any changes or modifications not expressly approved by the party responsible for compliance could void the user's authority to operate the equipment.

NOTE: This equipment has been tested and found to comply with the limits for a Class B digital device, pursuant to Part 15 of the FCC Rules. These limits are designed to provide reasonable protection against harmful interference in a residential installation. This equipment generates, uses and can radiate radio frequency energy and, if not installed and used in accordance with the instructions, may cause harmful interference to radio communications.

However, there is no guarantee that interference will not occur in a particular installation. If this equipment does cause harmful interference to radio or television reception,

which can be determined by turning the equipment off and on, the user is encouraged to try to correct the interference by one or more of the following measures:

- Reorient or relocate the receiving antenna.
- Increase the separation between the equipment and receiver.
- Connect the equipment into an outlet on a circuit different from that to which the receiver is connected.
- Consult the dealer or an experienced radio/TV technician for help.

To maintain compliance with FCC's RF Exposure guidelines, This equipment should be installed and operated with minimum 20cm distance between the radiator and your body: Use only the supplied antenna.



CUSTOMER SUPPORT

support@welovhome.com

www.welovhome.com